



CRISIS RESPONSE UNIT

C.R.U. MALAWI

ADDRESSING THE ROAD TRAFFIC FATALITY RATE IN MALAWI

GLOBAL STATISTICS ON RTI FATALITIES



MALAWI RANKS **1ST IN AFRICA** IN RTI MORTALITY AT **35**
FATALITIES PER 100,000 POPULATION.⁶

"Every second counts in a road traffic emergency. Reducing the time it takes for medical services, firefighters and rescuers to arrive on the scene can save lives and limit the severity of the consequences of road accidents for survivors."¹⁰

("New UN Regulation on Automatic Emergency Call System for Road Traffic Accidents Will Reduce Response Times, Save Lives." Targeted News Service, Nov 23, 2017.)

Every year, about 1.2 million people die through road traffic crashes worldwide. Majority of these deaths occur in Africa where most of their emergency medical services are underdeveloped.¹²



THE UNITED NATIONS RECOGNIZES THIS AS A GLOBAL
CRISIS AND HAS DEVELOPED A SUSTAINABLE DEVELOPMENT GOAL TO
COMBAT THIS.

BY 2020, **HALVE** THE NUMBER OF GLOBAL DEATHS AND INJURIES
FROM ROAD TRAFFIC ACCIDENTS.²

NATIONAL STATISTICS ON RTI FATALITIES

About 20 road traffic collisions occur every day in Malawi, two of which are fatal and two serious injuries. About 1,000 people are killed in road traffic crashes in Malawi every year. In 2015, 5,700 individuals died in Malawi from a road traffic accident despite there being only one motor vehicle on the road per 40 residents.^{6,14}

Death at the scene of crash may be related with either critical and maximum injury severity or poor post-collision care. Delay in emergency services, lack of ambulance services, and shortage of pre-hospital teams certainly contribute to deaths on scene.¹⁴

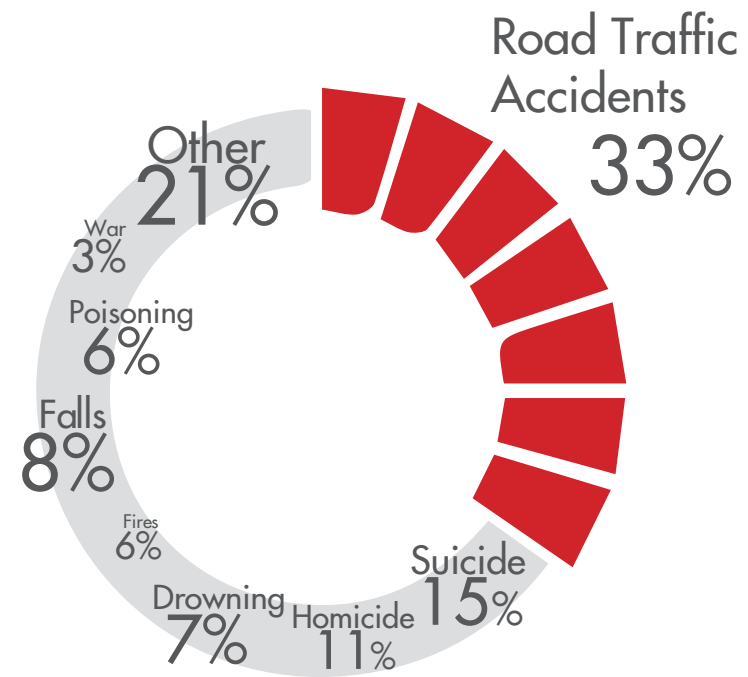

IN MALAWI, **1/3RD** OF **ALL INJURY RELATED DEATHS** ARE DUE TO ROAD TRAFFIC ACCIDENTS.⁶

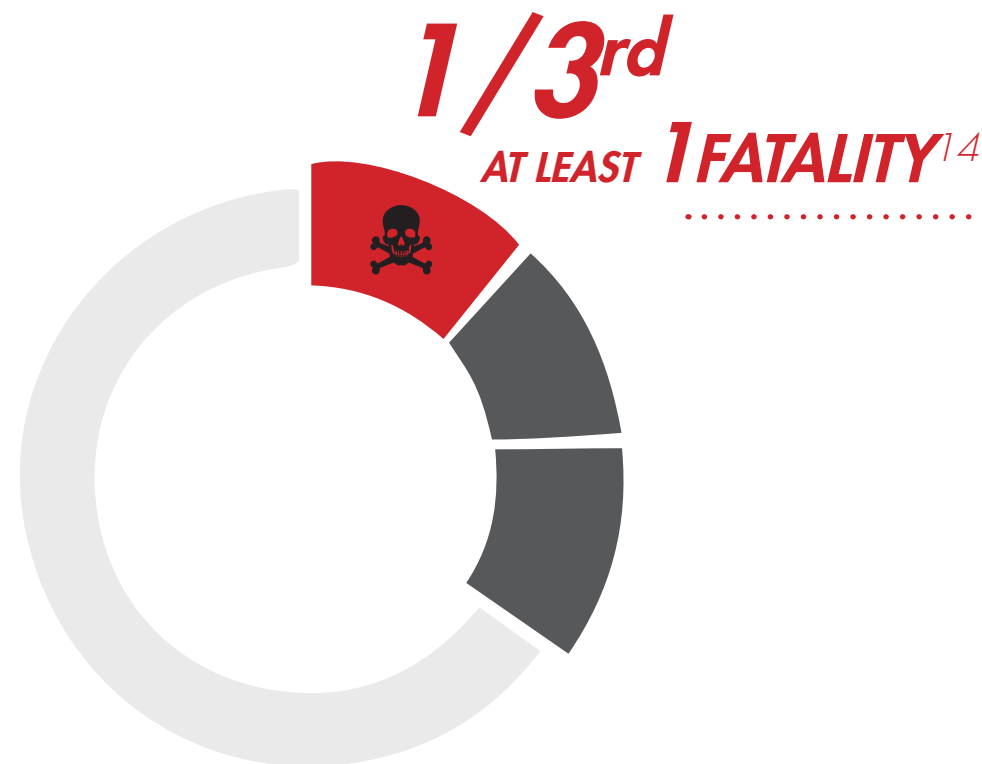

- A** CRITICAL AND MAXIMUM INJURY SEVERITY^{5,14}
- B** POOR POST-COLLISION CARE^{5,14}
 - i** delay in emergency medical attention¹⁴
 - ii** lack of ambulance services¹⁴
 - iii** shortage of pre-hospital teams¹⁴

THE TYPICAL RTI TIMELINE: 2-4 VICTIMS



Steps in the sequence from crash site to the healthcare facility



Issues encountered during the process



PEDESTRIAN
COLLISIONS¹⁴

FATAL CASES: **44%**¹⁴



BICYCLE
COLLISIONS¹⁴

FATAL CASES: **41%**¹⁴



MOTORCYCLE
COLLISIONS¹⁴

FATAL CASES: **41%**¹⁴

A ROAD TRAFFIC ACCIDENT

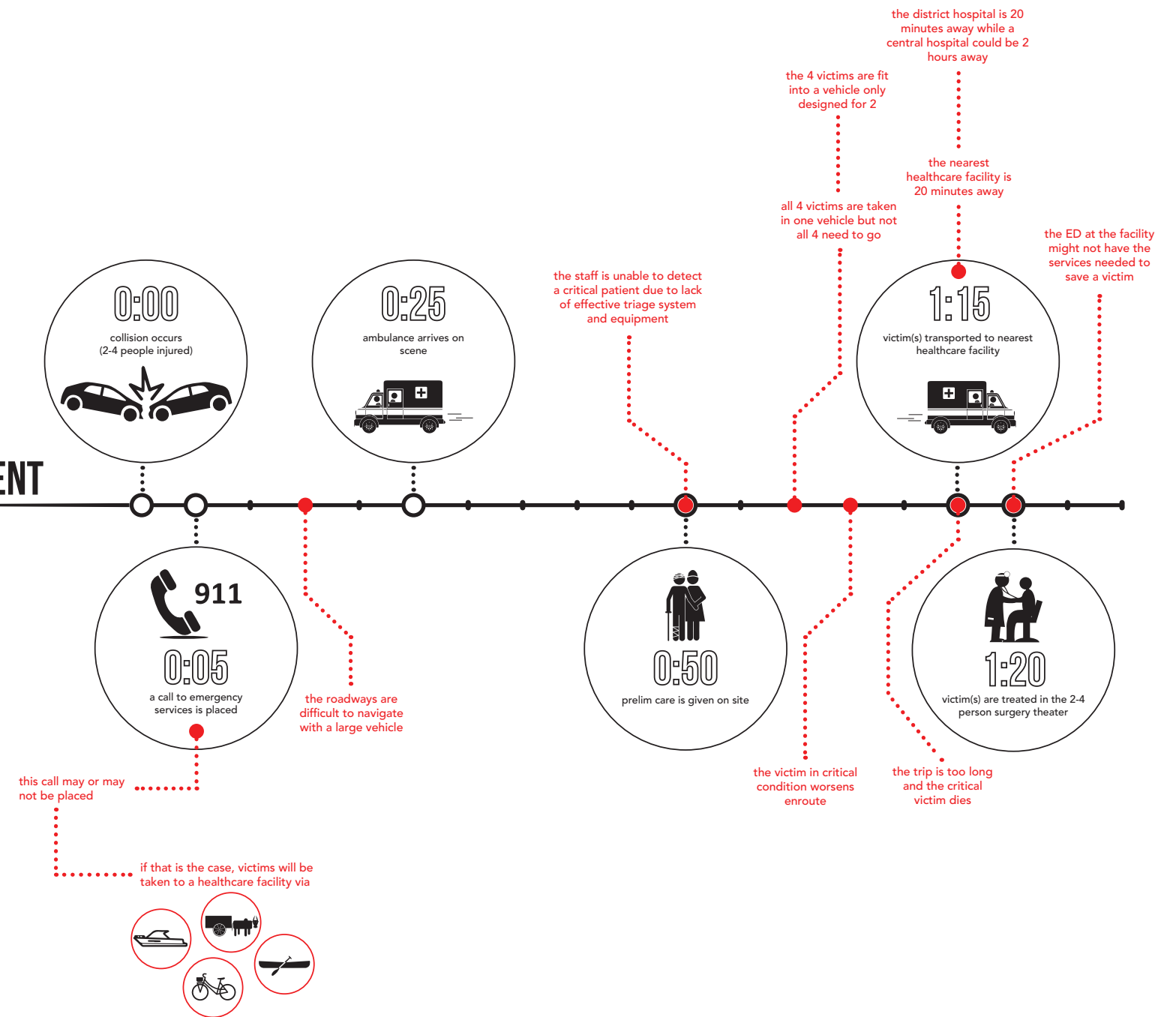

THE MASS CASUALTY

RTI TIMELINE:

20+ VICTIMS

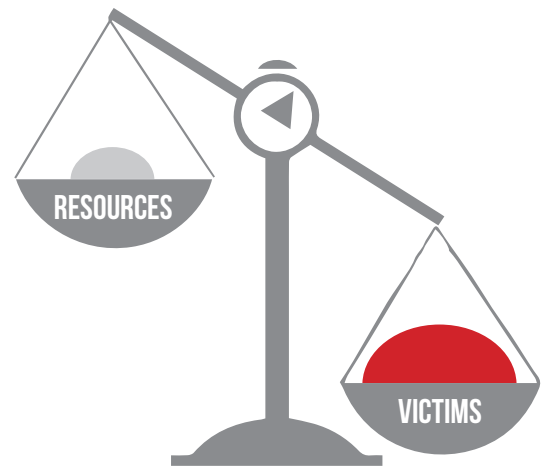

casualties
>>resources

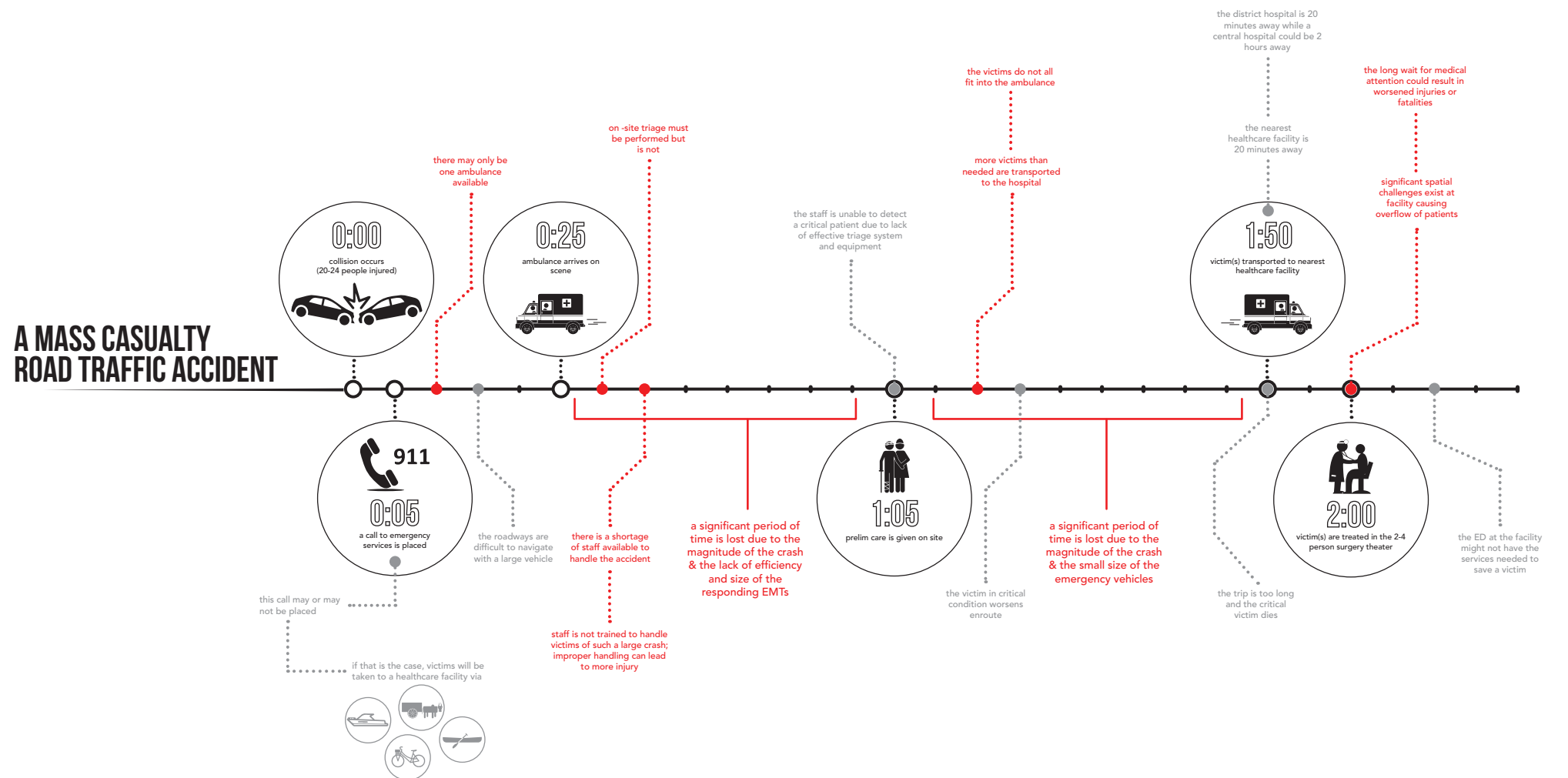

POINT OF INTERVENTION

A MASS CASUALTY ROAD TRAFFIC ACCIDENT

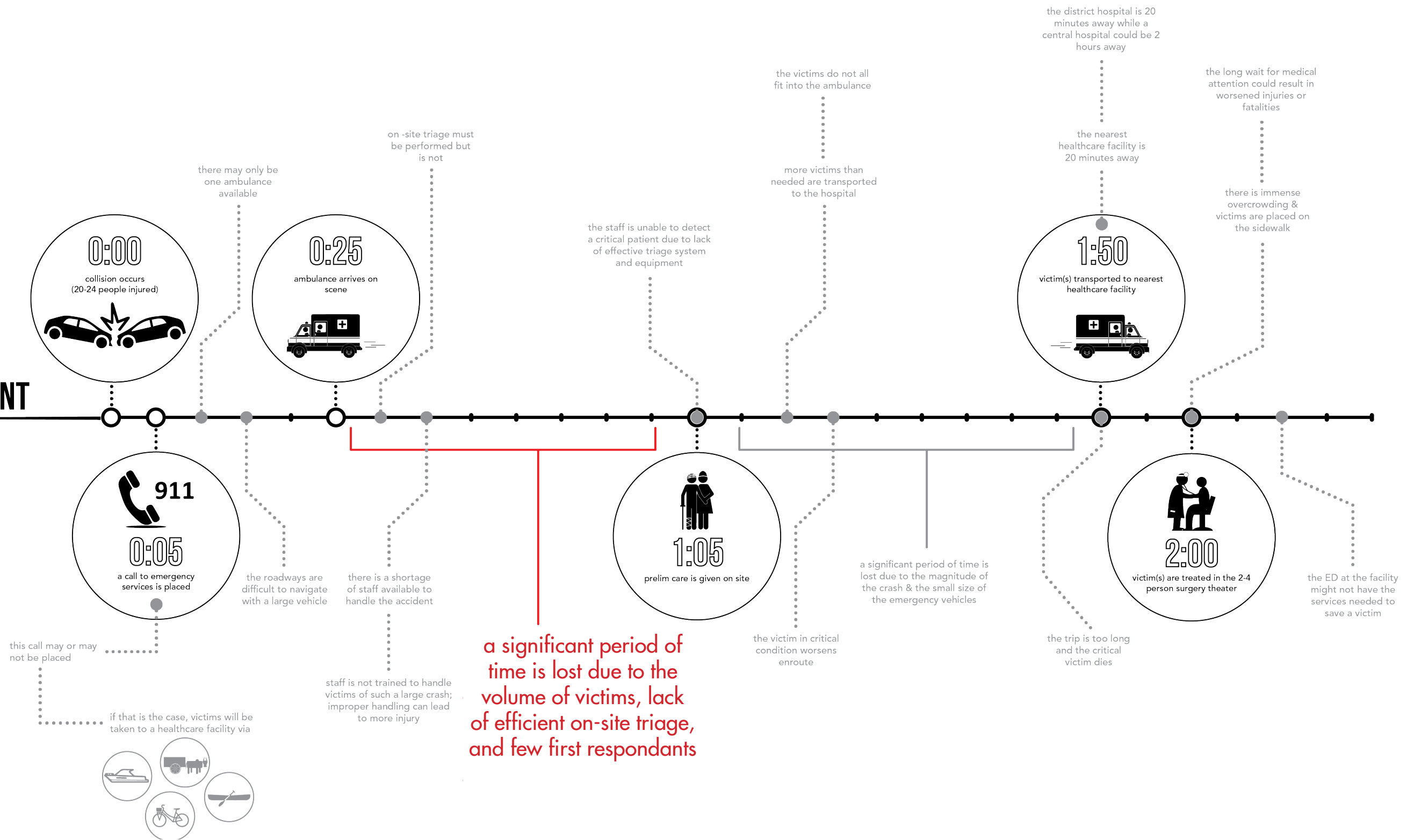

THESIS

&

RESEARCH QUESTION

"Emergency and trauma services within the country are at best disorganized and often non-existent."¹⁴

"Adequate post-collision care is key to reducing road fatalities on scene."¹⁴

"Primary intervention is widely believed to be the most appropriate strategy to prevent traffic collisions"¹⁴

"even a 10 minutes reduction of the medical response time can be statistically associated with an average decrease of the probability of death by one third"¹⁴

*Could a **deployable, pre-fabricated mobile emergency response unit** help reduce the on-site road traffic accident mortality rate?*

CRISIS RESPONSE UNIT C.R.U.

*ASSISTING THE
HEALTHCARE
PROVIDERS ON THE
CRASH SITE OF A
MASS CASUALTY
ROAD TRAFFIC
ACCIDENT*

*Providing a **quickly
deployable emergency
tent structure** to
conduct on-site triage
will improve efficiency
of healthcare given at
the crash-site.*

MAJOR COMPONENT RELATIONSHIPS

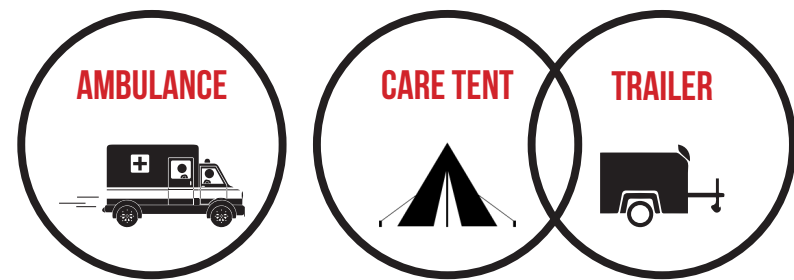

THE AMBULANCE IS ITS OWN ENTITY

THE CARE TENT & TRAILER ARE ONE ENTITY.

This allows the ambulance to leave with a critical patient while the emts handle other victims with minor injuries.

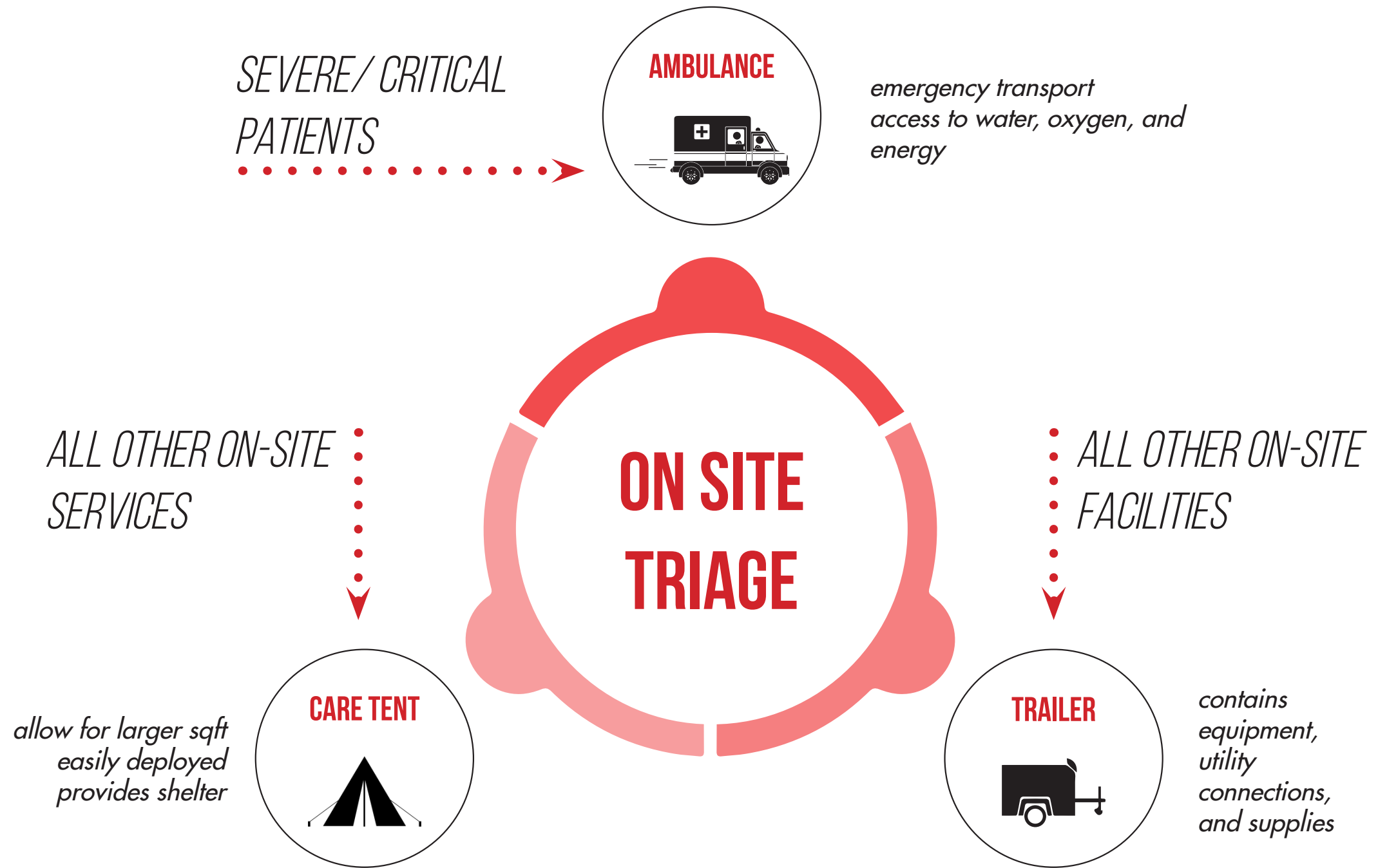

CRISIS RESPONSE UNIT CRITERIA

As the tent is developed, it is critical to set up criteria which can be used to assess the success or failure of the proposed solution.

However, we must also accept that not all of the criteria might be able to be incorporated into a solution. The challenge of this proposal lies in the question of compromise.

DEPLOYMENT CRITERIA



FLEXIBILITY OF
VEHICLES



RATE OF
ASSEMBLY

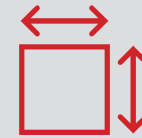

SQUARE
FOOTAGE



STORAGE
& ENERGY
CAPABILITY



VOLUME
OF STORED
STRUCTURE



WEIGHT OF TENT
STRUCTURE



TYPE OF
INTERNAL
SPACE

STRUCTURAL CRITERIA



REQUIRED
MANPOWER



REPETITIVE
DEPLOYMENT

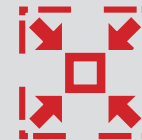

COMPACTION
ABILITY



PROVIDES SUN-
SHADING



WATERPROOF
MATERIALS



WEIGHT OF
OVERALL
STRUCTURE



AFFORDABLE
MATERIALITY

PROGRAMMATIC CRITERIA



SIMPLE TRIAGE
AND RAPID
TREATMENT

 IMMEDIATE
  DELAYED
  MINOR

TRIAGE ADJACENCIES &
PRIORITIZATION



UTILITY
CONNECTIONS



STORAGE ROOM
FOR SUPPLIES



APPROPRIATE
LIGHTING



CLEAR
SIGNAGE
FOR TRIAGE

PREFAB

&

SHIPPING

STRATEGY

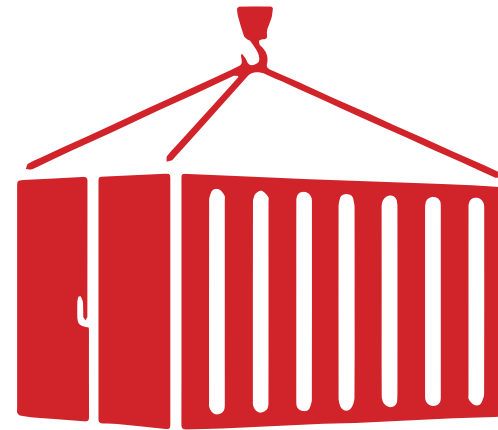

ONE OF THE GOALS FOR THIS PROJECT WAS TO CREATE A

PREFABRICATED, SHIPPABLE DESIGN.

ALL COMPONENTS OF A 2-UNIT SET WOULD BE ABLE TO FIT INSIDE A 45'

LONG SHIPPING CONTAINER.

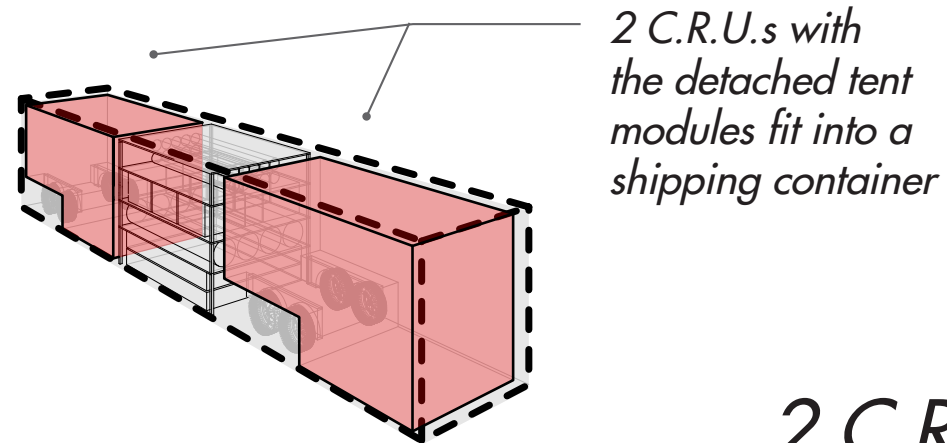

2 C.R.U.s with
the detached tent
modules fit into a
shipping container

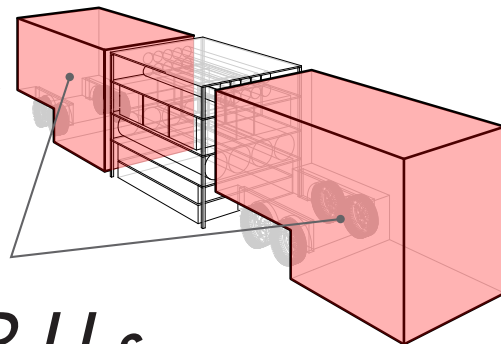

2 C.R.U.s

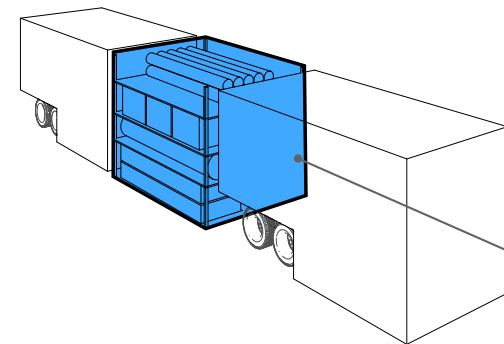

structure
supplies
tent fabric
supplementary

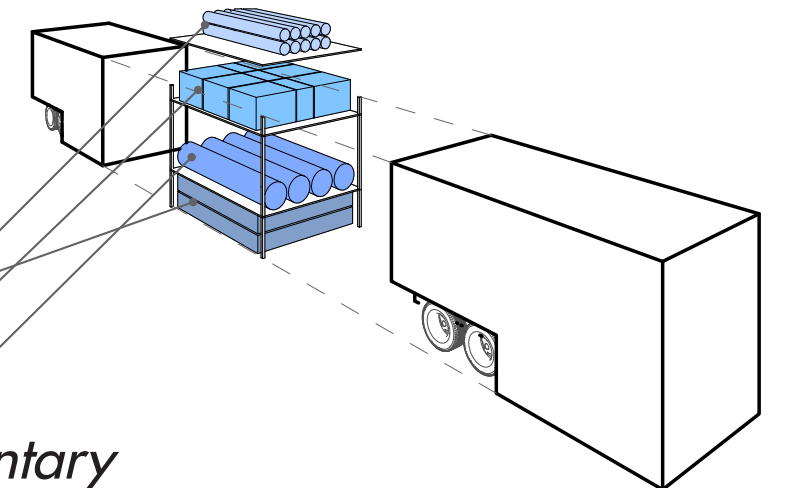

SEQUENCE

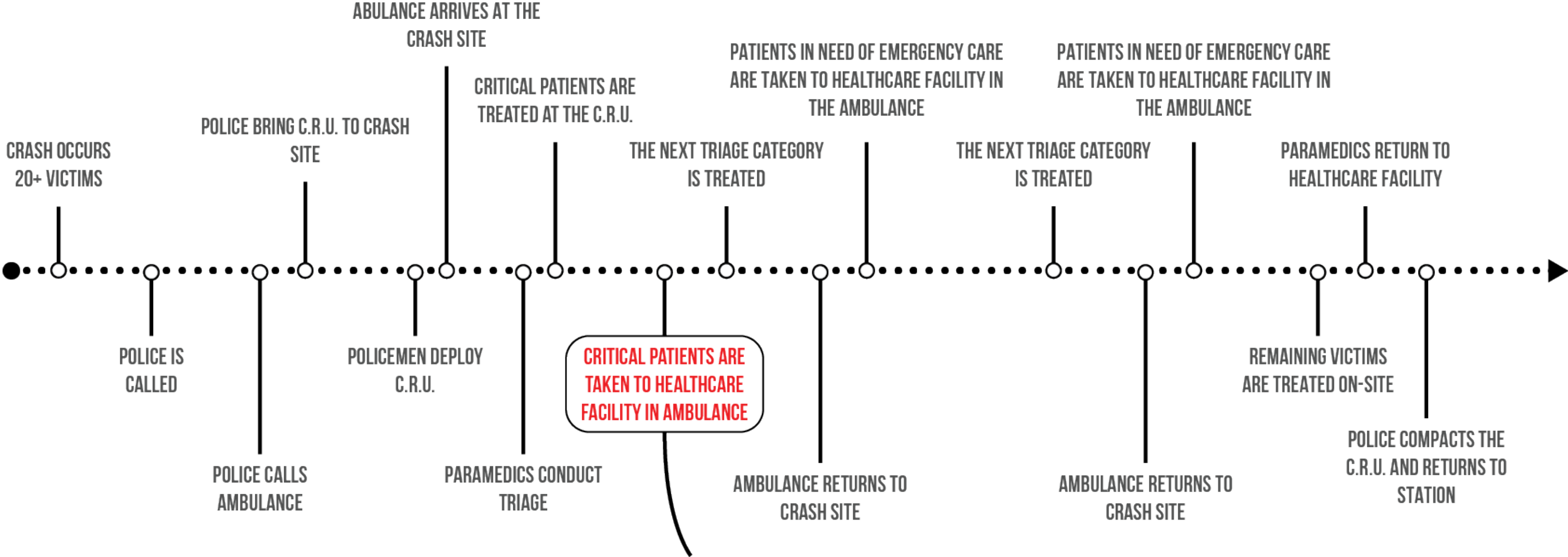

THIS ACHIEVES THE GOAL OF TRANSPORTING THE MOST CRITICAL VICTIMS TO A FACILITY OF DEFINITIVE HEALTHCARE, REDUCING THE ROAD TRAFFIC MORTALITY RATE.

CRISIS RESPONSE UNIT (C.R.U) CONTENTS

*The C.R.U. is divided into two phases:
the treatment zone & the storage zone*

*The deployable tent is located on top of the
treatment zone of the C.R.U.*

*The electric, oxygen, and water connections are
located towards the front of the trailer over the
hitch to ensure the most stability and safety.*

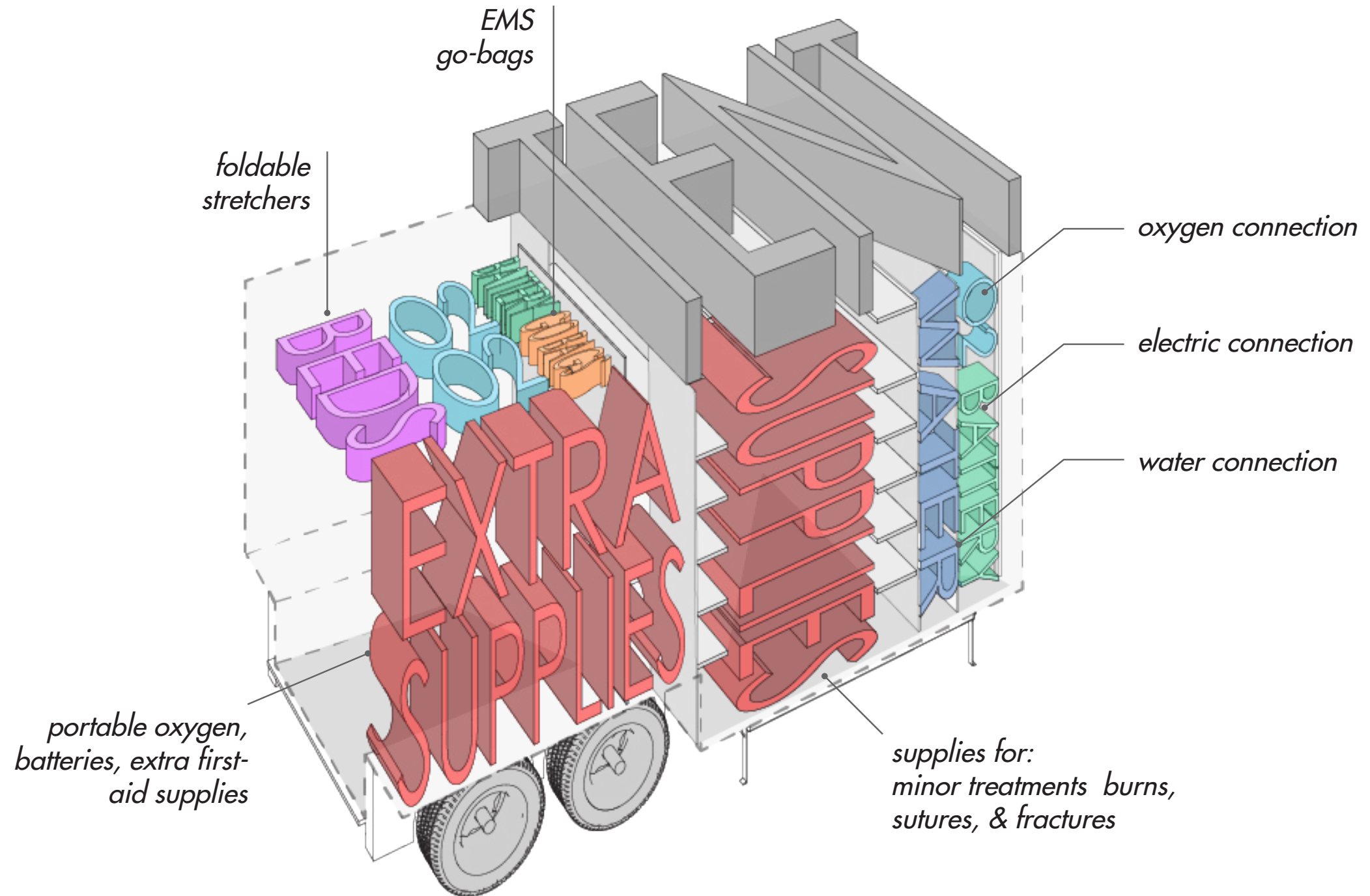

C.R.U. EXPLODED AXON FEATURES

Based on multiple conditions that the system could encounter, various features were included in the C.R.U.

Things such as a fabric which allows some light transmission but definitely stops rain and a light system along the top of the C.R.U. for night-time emergencies are included.

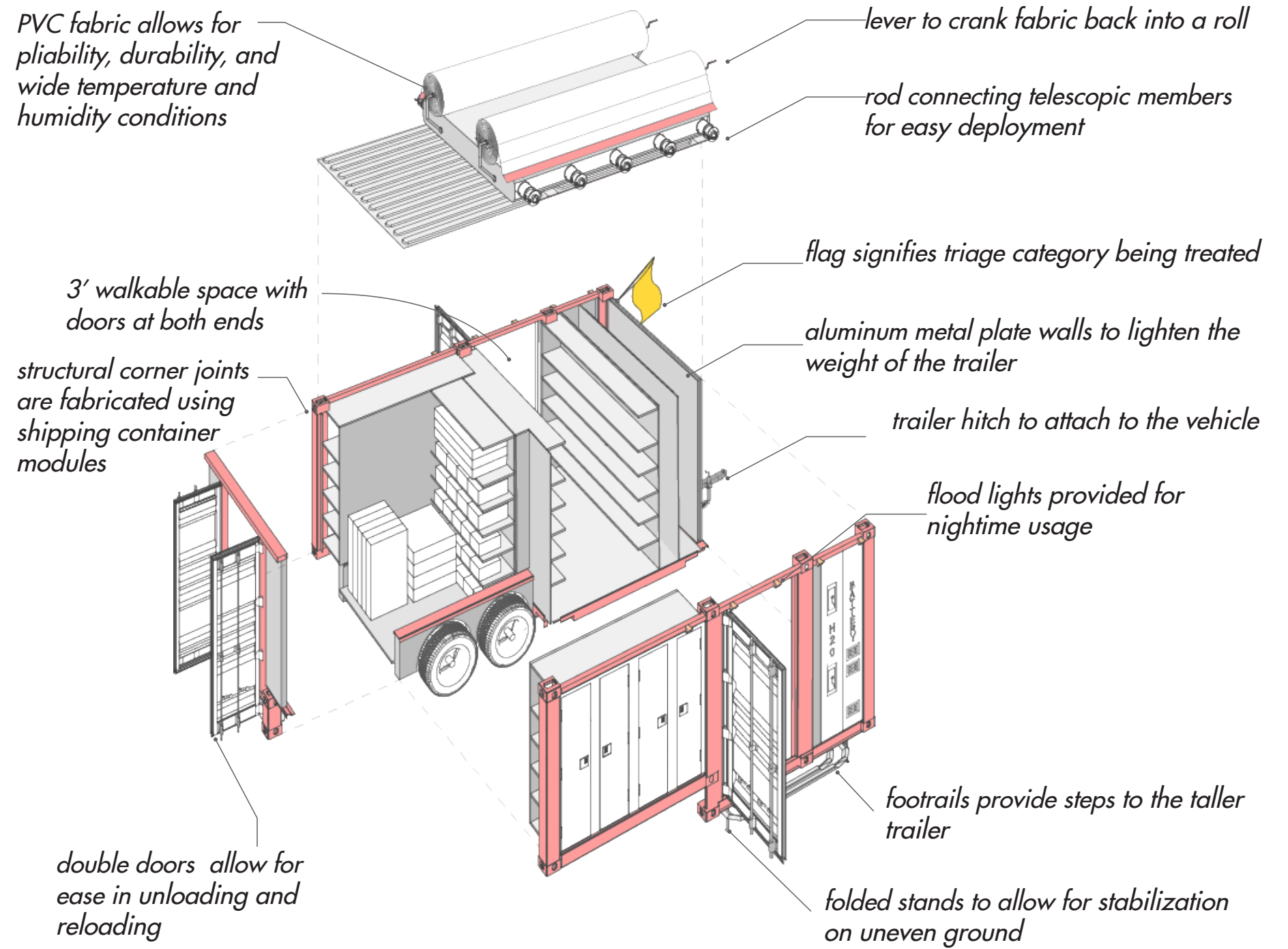

FLOOR PLAN

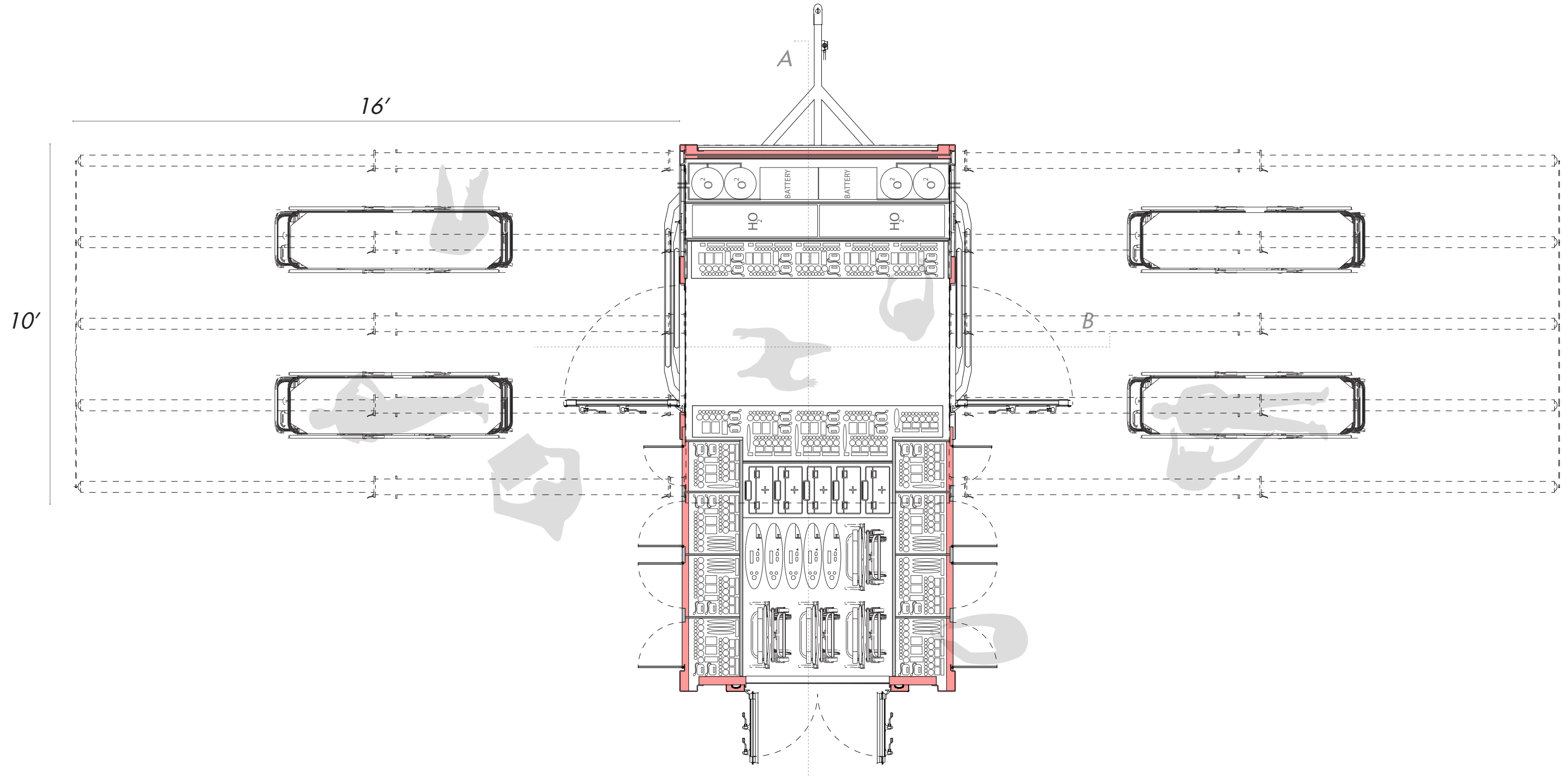

ELEVATION

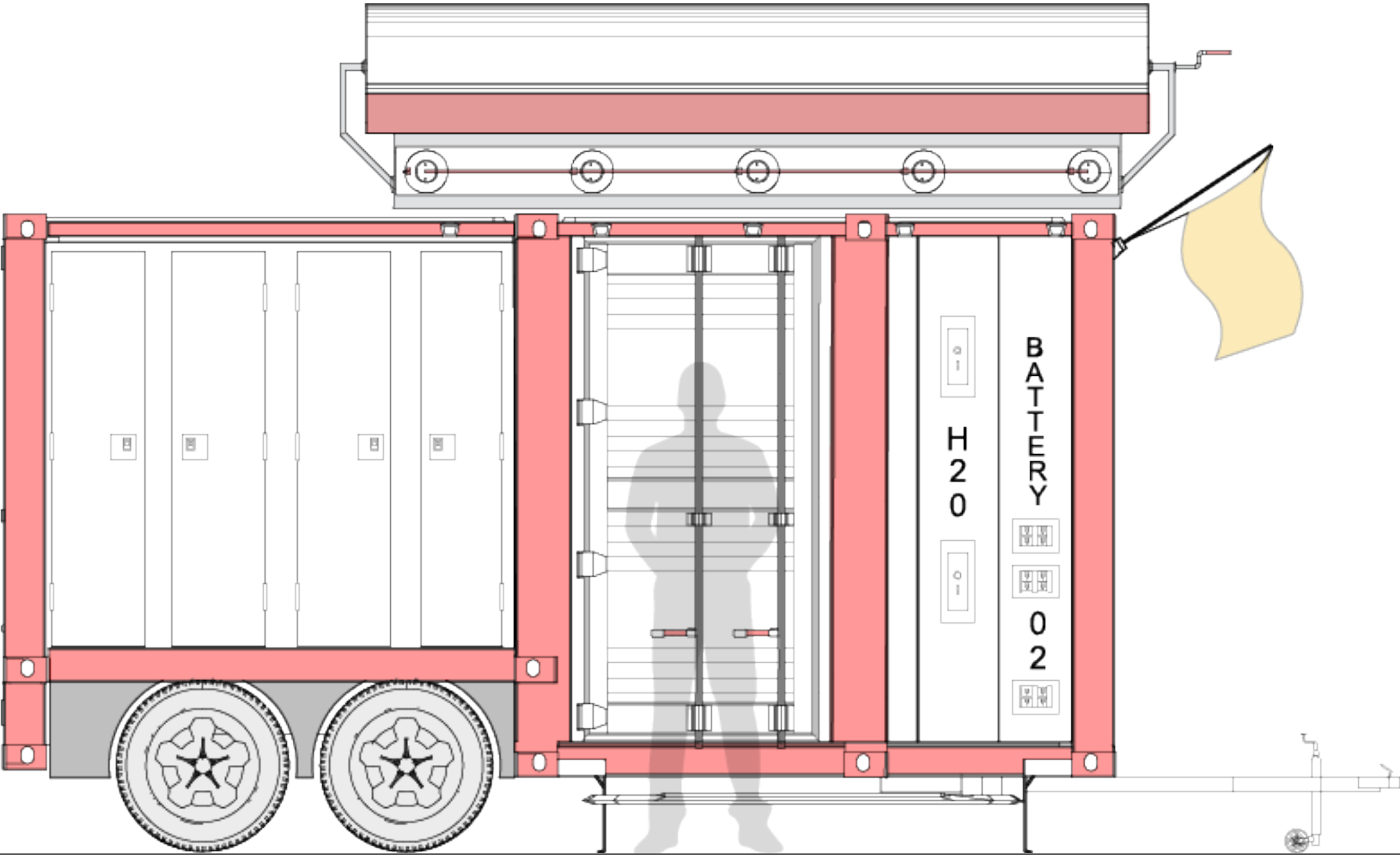

SECTION A

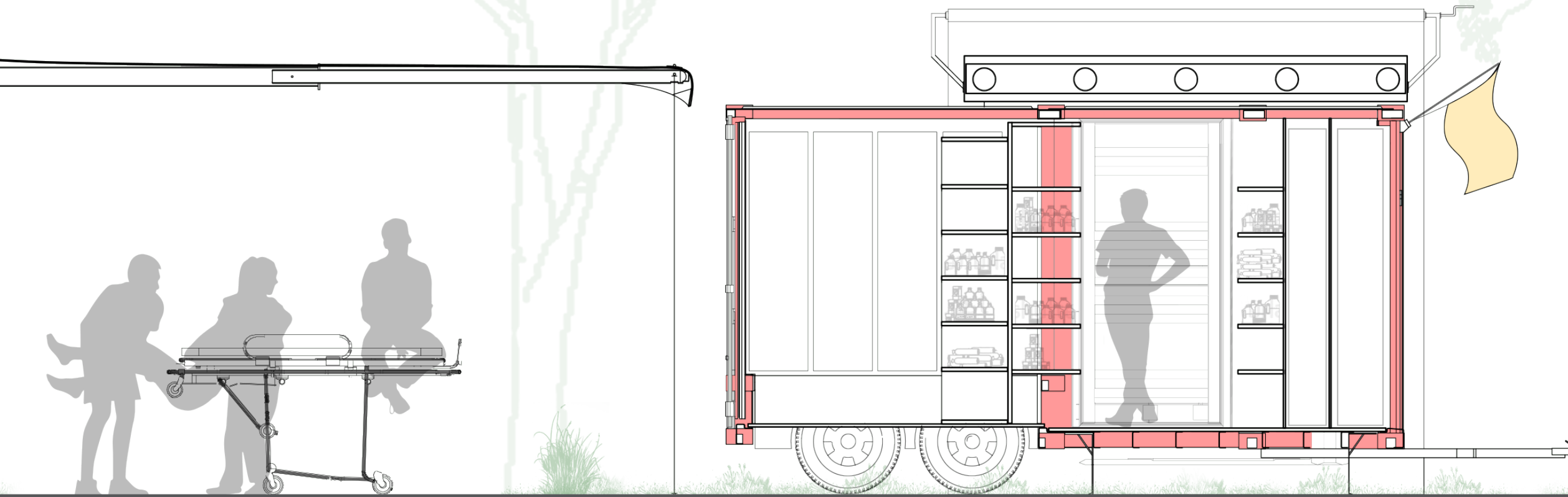
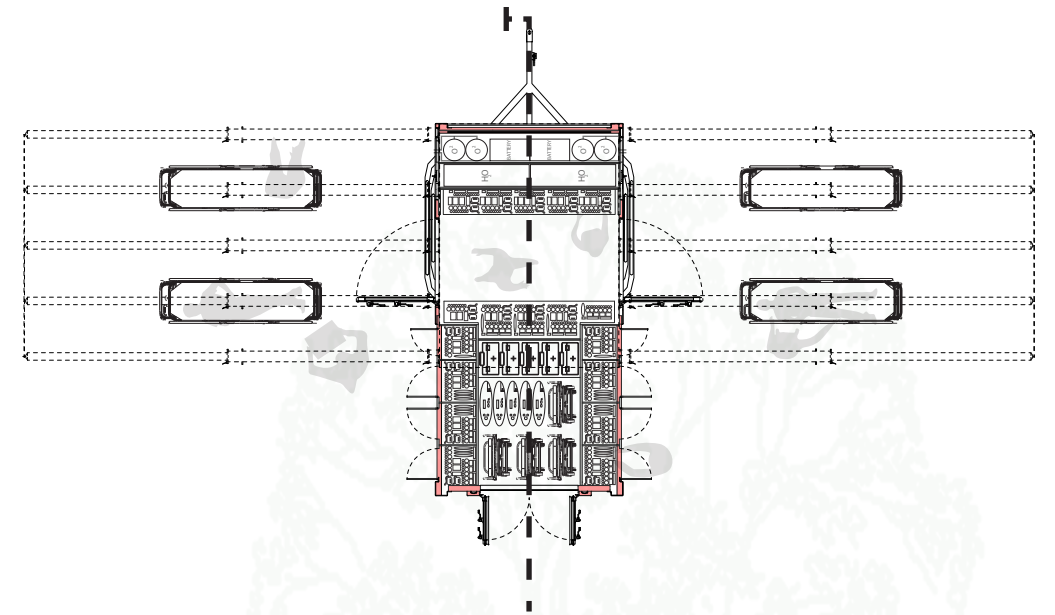

SECTION B

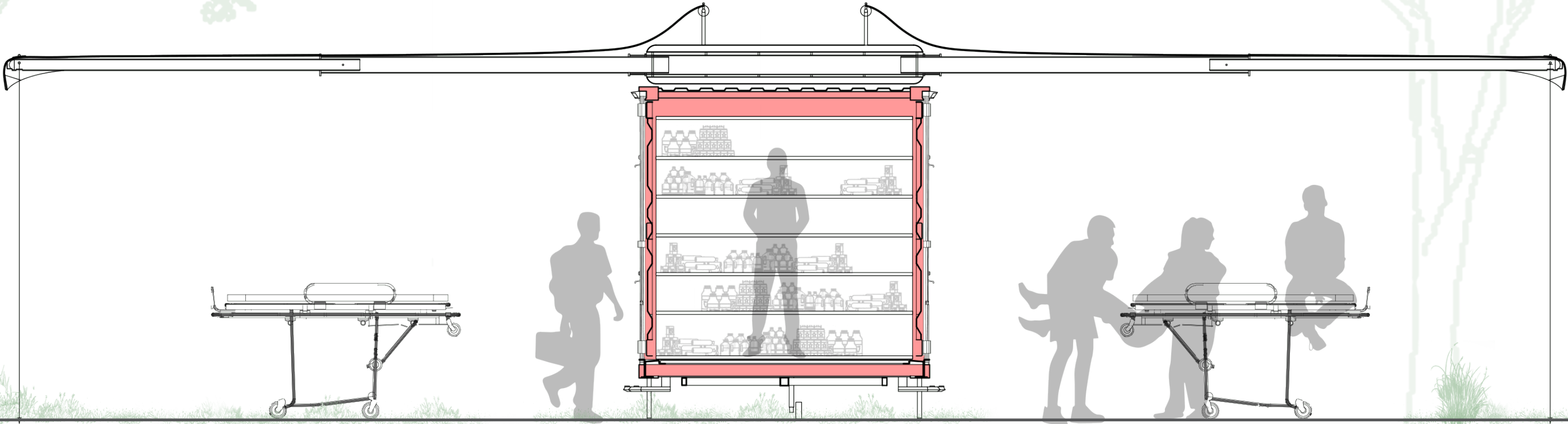
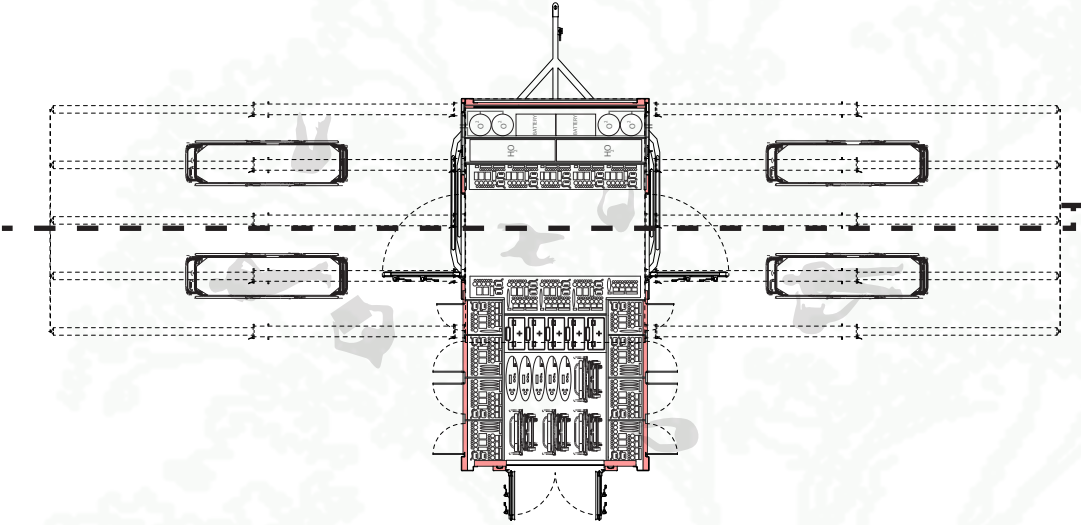

SECTION B

LOAD DIAGRAM

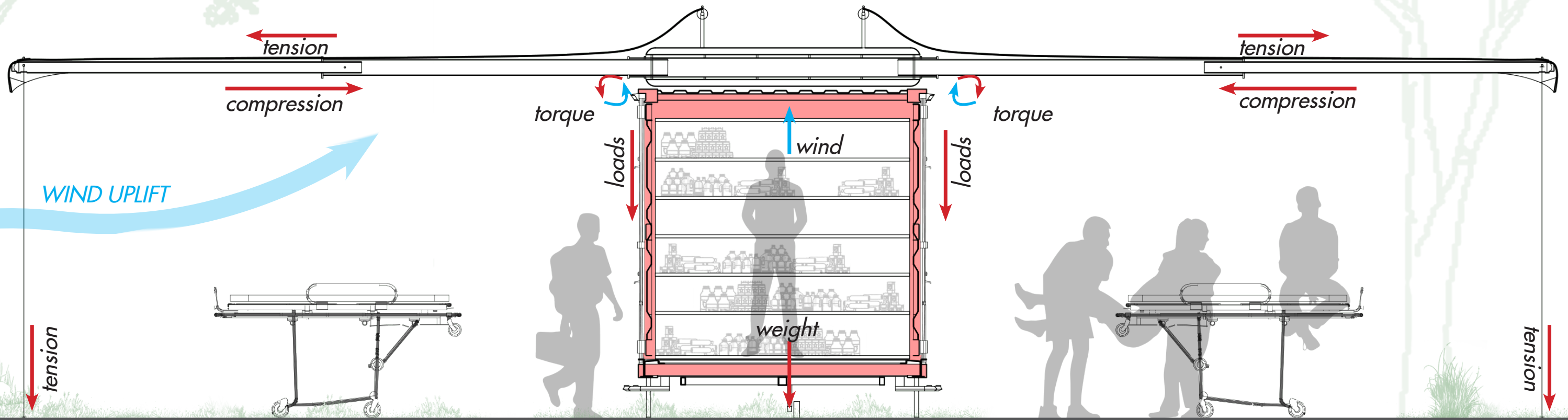
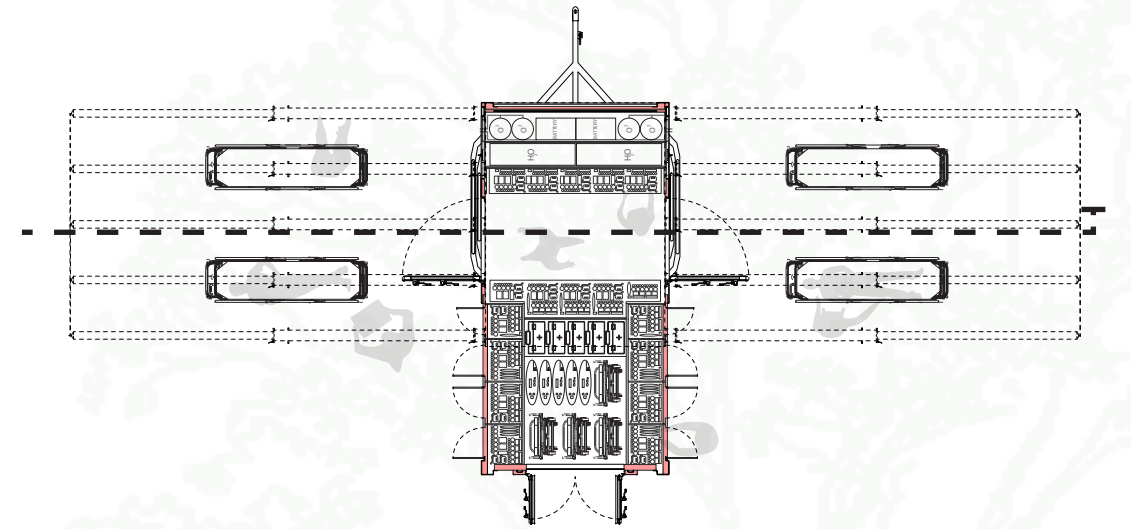

OVERALL SYSTEM

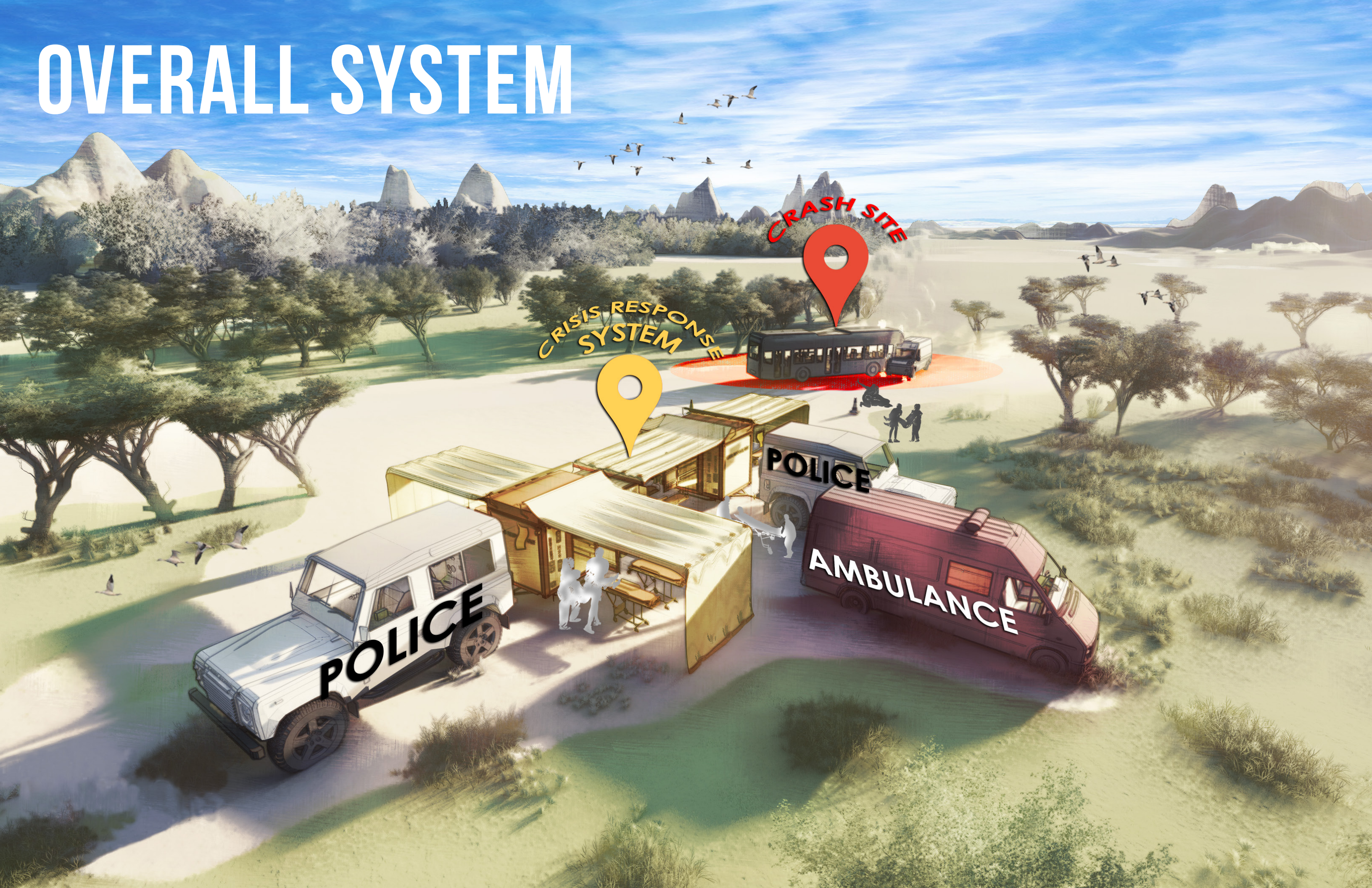

CRISIS RESPONSE SYSTEM

CRASH SITE

POLICE

POLICE

AMBULANCE

CIRCULATION THROUGH C.R.U. ON-SITE

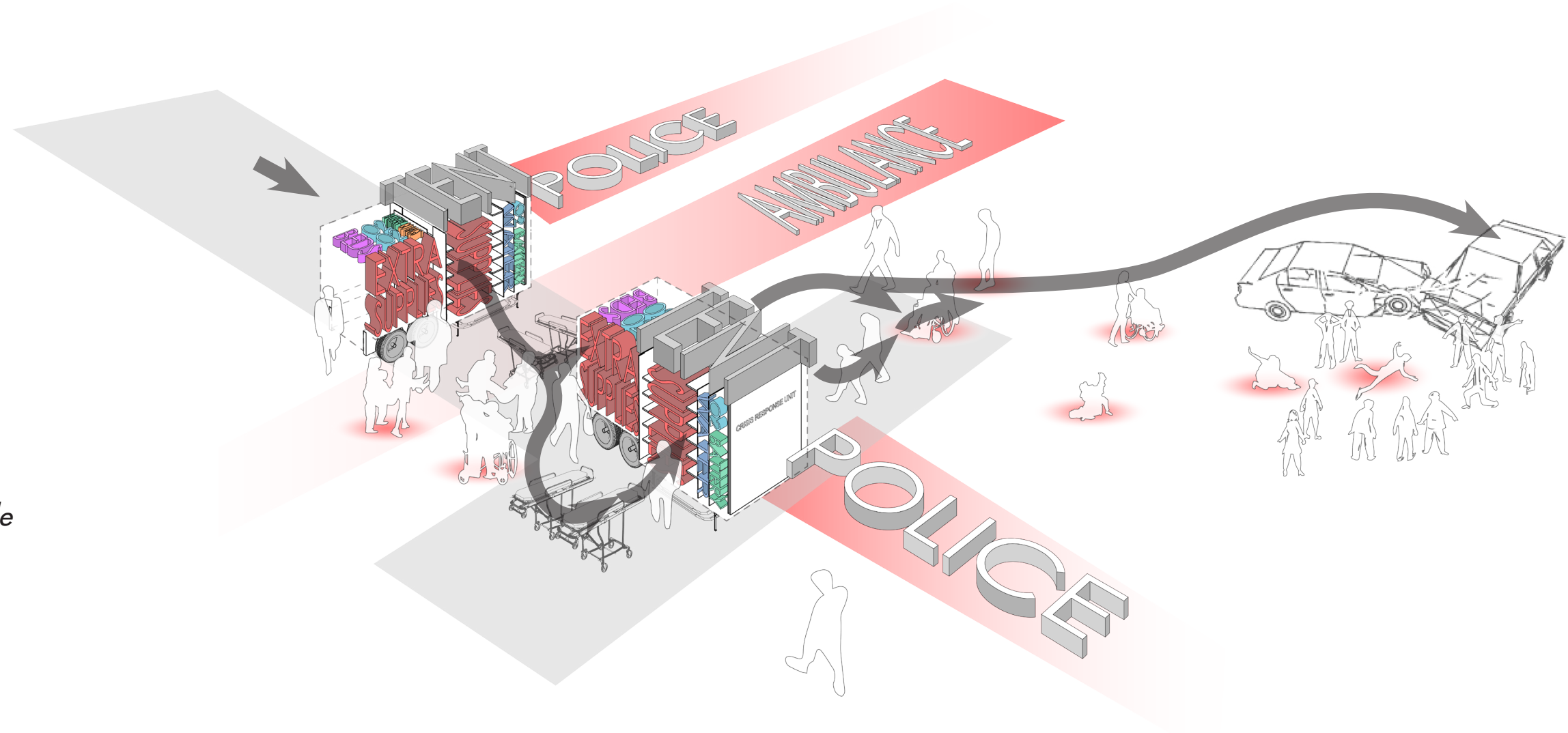



The crisis response units are designed to be able to be walked through and create a continuous circulation path on-site.

The deployed tent structure covers the area of treatment directly above the utility connections and supply corridor. The circulation flows through the supply corridor of one C.R.U. to a treatment area in front of the storage space with portable oxygen tanks, batteries, and go-bags.

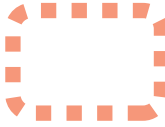

i.e. the treatment zones are perpendicular to the storage zones creating a space with all available supplies in the perimeter: the critical zone

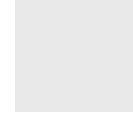
ZONES CREATED USING C.R.U.

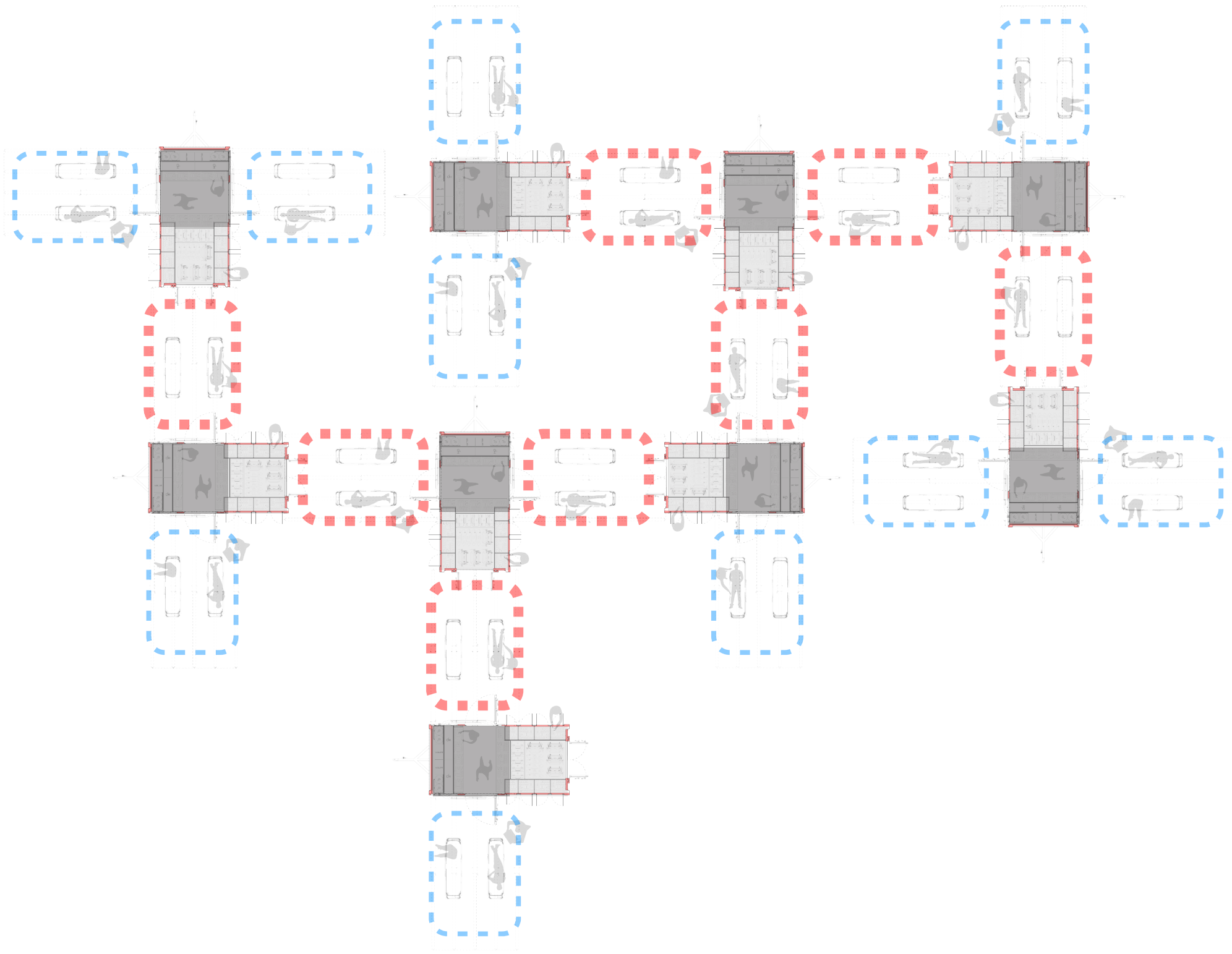
-  *Critical Treatment Zones*
-  *Treatment Zones*
-  *Supply & Utility Zones*
-  *Storage Zones*

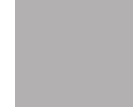
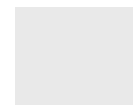

STAFF CIRCULATION WITHIN C.R.U.

-  Staff Circulation
-  Patient Circulation
-  Supply & Utility Zones
-  Storage Zones

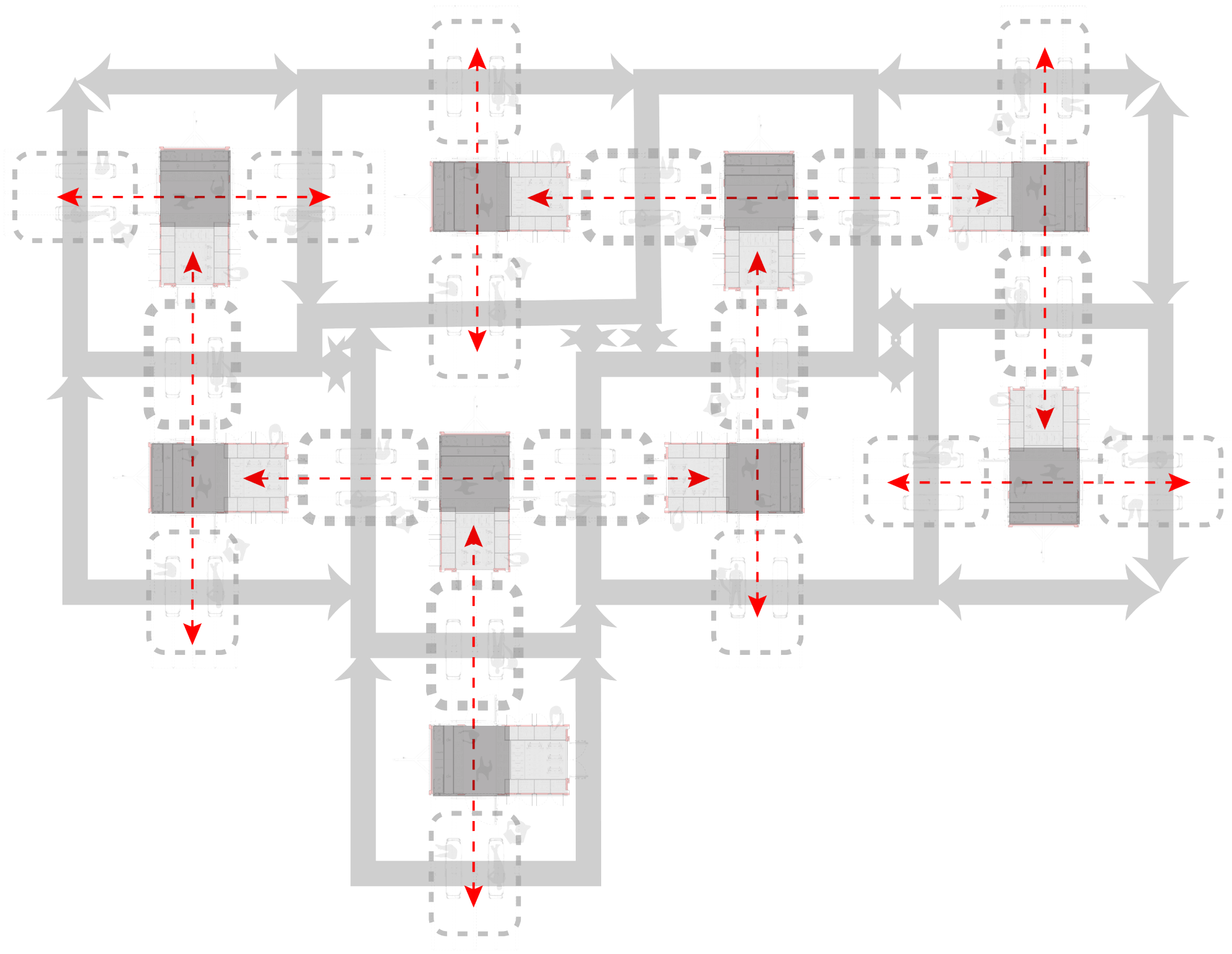







C.R.U. MALAWI



WORKS CITED

- 1 *Branas, C. C., E. J. MacKenzie, and C. S. ReVelle. 2000. A trauma resource allocation model for ambulances and hospitals. Health Services Research 35 (2): 489-507.*
- 2 "Goal 3: Good Health and Well-being." UNDP. Accessed February 10, 2019. <http://www.undp.org/content/undp/en/home/sustainable-development-goals/goal-3-good-health-and-well-being.html#targets>.
- 3 *Harrison, Hooi-Ling, Nigel Raghunath, and Michele Twomey. 2012. Emergency triage, assessment and treatment at a district hospital in malawi. Emergency Medicine Journal : EMJ 29 (11): 924-5.*
- 4 *HDT Global. Accessed February 27, 2019. <http://www.hdtglobal.com/series/medical-emergency-operations/>.*
- 5 *Lynn, Mauricio. "Hospital Planning and Response to Sudden Mass Casualty Incidents." Mass Casualty Incidents, 2016, 25-55. doi:10.1007/978-1-4939-3496-6_3.*
- 6 "Malawi." World Health Organization. February 01, 2015. Accessed February 11, 2019. <https://www.who.int/gho/countries/mwi/en/>.
- 7 "Model Comparison Chart." Demers Ambulances. Accessed February 27, 2019. <https://www.demers-ambulances.com/model-comparison-chart/>.
- 8 *Mohammed-Najeeb Mahama, Ernest Kenu, Delia Akosua Bando, and Nuhu Zakariah Ahmed. "Emergency Response Time and Pre-Hospital Trauma Survival Rate of the National Ambulance Service, Greater Accra (January – December 2014)." BMC Emergency Medicine 18, (2018). doi:http://dx.doi.org/10.1186/s12873-018-0184-3.*
- 9 *"New UN Regulation on Automatic Emergency Call System for Road Traffic Accidents Will Reduce Response Times, Save Lives." Targeted News Service, Nov 23, 2017.*
- 10 "Rapid Deployment Shelters For Sale | HTS." Roder HTS USA. Accessed February 11, 2019. <https://www.hts-usa.com/products/rapid-deployment-shelters/>.
- 11 "Road Traffic Deaths." World Health Organization. March 11, 2016. Accessed February 12, 2019. https://www.who.int/gho/road_safety/mortality/en/.
- 12 *Rivas-Adrover, Esther. (2015). Deployable Structures.*
- 13 *Schlottmann, Francisco et al. "Road traffic collisions in Malawi: Trends and patterns of mortality on scene" Malawi medical journal : the journal of Medical Association of Malawi vol. 29,4 (2017): 301-305.*
- 14 "SHELTERPOD (RED) Limited Edition." SHIFTPOD | Advanced Shelter Systems Inc. Accessed February 11, 2019. <https://store.advancedsheltersystemsinc.com/responsepod/shelter/shelterpod-r>.
- 15 *Sion, Melanie, MD, and Anthony Charles, MD, MPH, FACS. Central Malawi District Hospital Surgical Capacity Assessment. Report. Department of Surgery, Thomas Jefferson University Hospital.*
- 16 "What Is a Mass Casualty Incident?" Classification of Social Media Platforms. Accessed February 27, 2019. <https://delvalle.bphc.org/mod/wiki/view.php?pageid=89>.
- 17 [https://www.who.int/bulletin/archives/80\(11\)900.pdf](https://www.who.int/bulletin/archives/80(11)900.pdf)